



NDC SERIES STEPPING MOTOR DRIVES

1/8

PRELIMINARY

1) GENERAL CHARACTERISTICS

| NDC | NDC 04 NDC 04.V | NDC 06 NDC 06.V | NDC 94 | NDC 96 |
|-------------------------|------------------------------------|--------------------|----------------|---------------|
| V _{DC} nom (V) | from 24 to 75 | from 24 to 75 | from 24 to 75 | from 24 to 75 |
| I _{NP} min (A) | 0.65 | 1.9 | 0.65 | 1.9 |
| I _{NP} max (A) | 2 | 6 | 2 | 6 |
| Dimensions (mm) | 93.5 × 101 × 25 | | 110 × 108 × 34 | |
| Operating temperature | from + 5°C to + 45°C (see point 7) | | | |

Table 1

Terms definition in Table 1

- V_{DC} nom** Nominal value of DC voltage supply (range) at which the drive can operate without stabilized supply.
- I_{NP}** Nominal phase current (peak value) which flow in each motor winding, measurable with motor turning at low speed. This current can be selected by user among eight different values using DIP-SWITCHES. Automatic current reduction at motor standstill is 50% of value set using DIP-SWITCHES.
- I_{NP} min and max** Minimum and maximum value of nominal phase current setting.

2) LOGIC INPUT AND OUTPUT SIGNALS (connectors AM3 or C2, see Fig. 1, 7, 9 and 10)

All inputs and outputs are optically insulated (mutually and respect to internal power circuit). For all inputs and outputs you have both positive and negative terminal. The input corresponding to 6 and 7 terminals has different function in STEP operation mode and in RUN operation mode (set using OS jumper).

Driving an input with a slow signal (i.e. relays) or with variable delay (i.e. PLC output) can give precision problem or, worse, make the board do not work at all. If you have this type of signal, contact R.T.A.

- 2(-) ; 3(+)** **CURRENT OFF INPUT:** When this signal is ON drive is active. When it is OFF drive is inhibited, thus motor current (and so holding torque) is turned to zero. **With jumper CO this input is always ON** (drive is always active).
- 4(-) ; 5(+)** **DIRECTION INPUT:** With this signal ON motor rotation direction is opposite to the one obtained with input OFF. This signal has to be valid at least 100 µsec. before STEP signal (or ENABLE signal) and has to stay in this state for at least 100 µsec. after last step sent to the drive (or ENABLE input disabled).
- 6(-) ; 7(+)** **STEP INPUT (STEP operation mode):** Step is performed on ON-OFF transition of this signal. Suggested duty-cycle: 50%. Max. frequency: 60 KHz with square wave signal supplied from a source with voltage between 3.5 and 13 Volt. In any case STEP signal half period has to be higher than 8 µsec.

ENABLE INPUT (RUN operation mode): When this signal is ON, motor rotate in the direction set by DIRECTION signal. When this signal is OFF the motor stops and after adjustment it keeps the load blocked with the torque at 50% of the set value (automatic current reduction). The maximum delay at enabling or disabling is lower than 1.5 millisecc. In case a revolution time lower than 20 millisecc is needed. command circuit has to be realized very carefully and thus it is suggested to contact RTA.

8(-) ; 9(+) **DRIVER FAULT OUTPUT:** When this output is SHORTED, drive is normally working; when it is OPEN drive is in no-working state. Drive automatically goes in no-working state when some protection is active and automatically recovers when the protection resets.

1 ; 10 **INTERNAL GND:** (internally interconnected and connected to terminals 12, 13 and 18). Galvanically insulated from logic inputs and outputs and connected to power supply common. They can be used to connect the shield of logic signal cable (if that is mandatory or useful depending on type of control system).

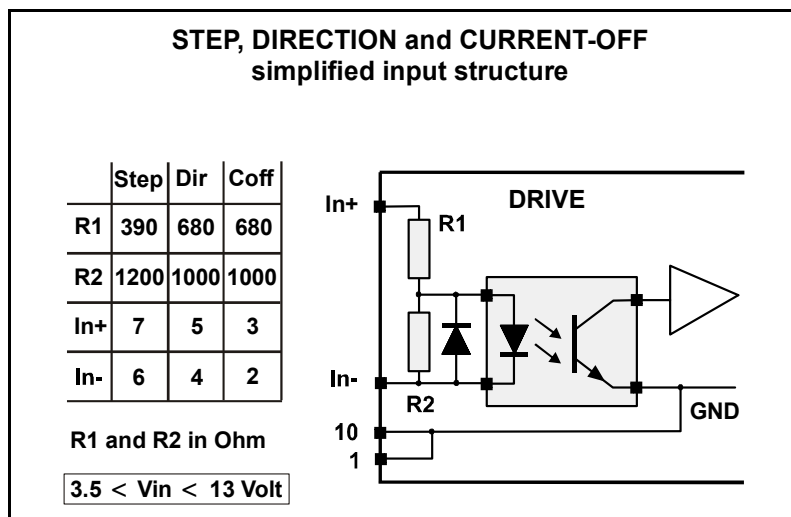

Fig. 1 a

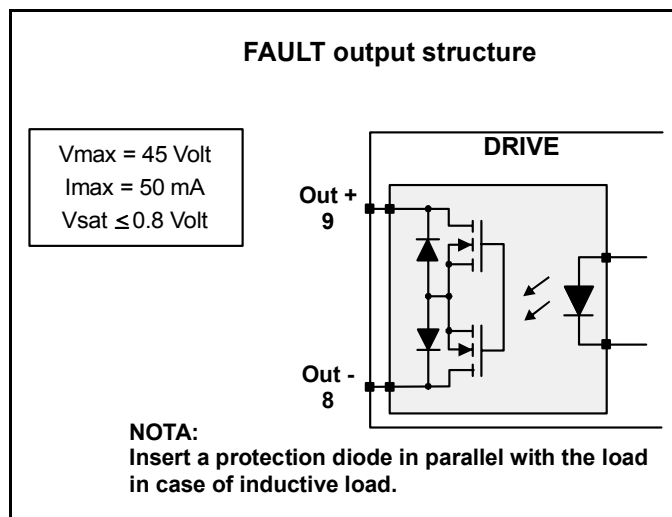

Fig. 1 b

CONNECTION EXAMPLES

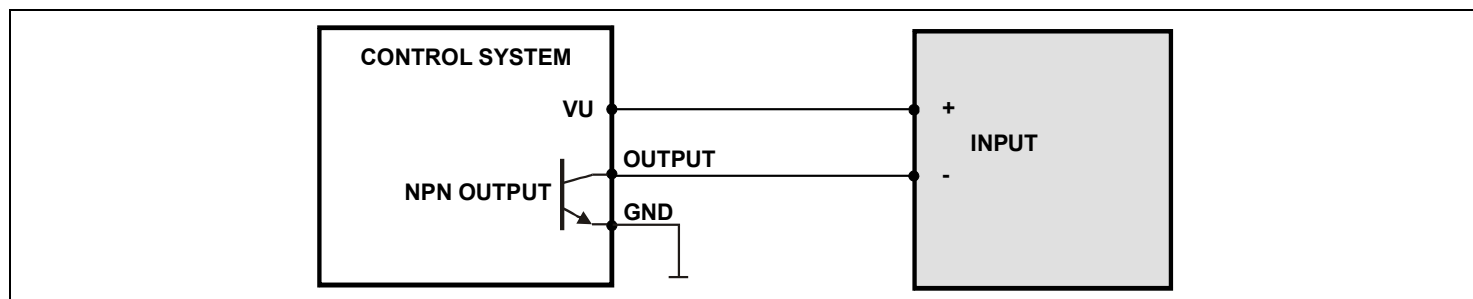

Fig. 2 Connection example with control system with NPN output.

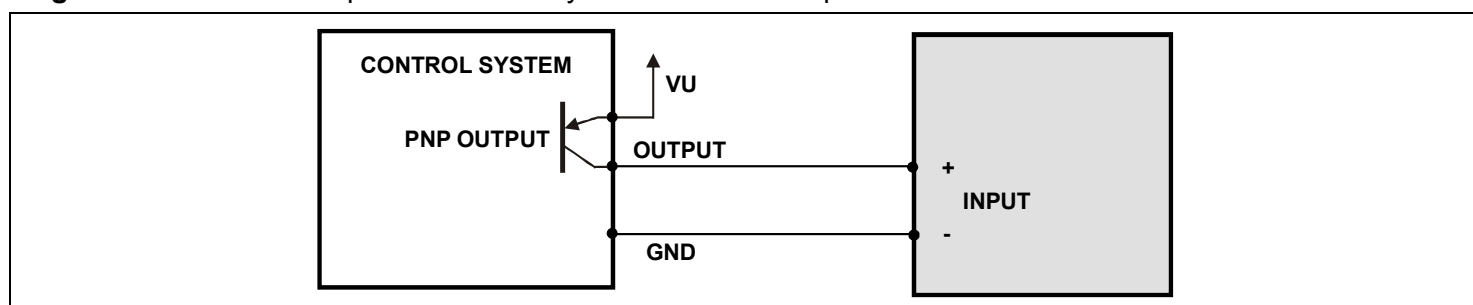

Fig. 3 Connection example with control system with PNP output.

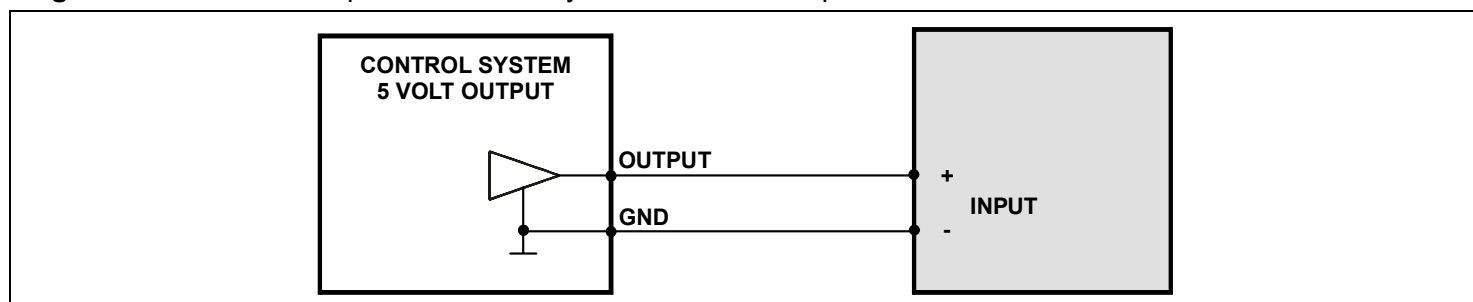

Fig. 4 Connection example with control system with 5 Volt TOTEM-POLE (PUSH-PULL) output.

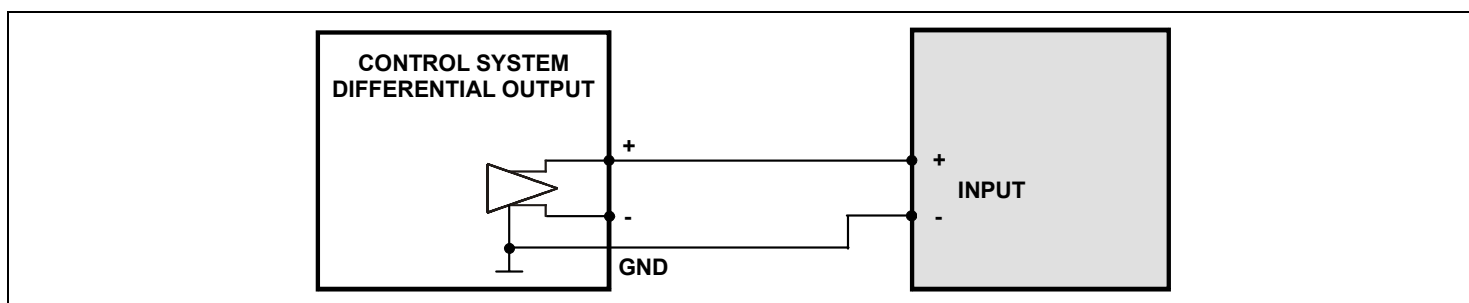

Fig. 5 Connection example with control system with DIFFERENTIAL output (or LINE DRIVER or RS422).

3) POWER INPUTS AND OUTPUTS (AM1 and AM2 or C1 connectors; see Fig. 7, 9 and 10)

- 11 - Power supply positive pole. (+ $V_{DC\ nom}$).
- 12 - Power supply negative pole. (- $V_{DC\ nom}$).
- 13 - GROUND; connect to Protective Earth terminal (PE).
- 14 - Motor winding terminal **B-**
- 15 - Motor winding terminal **B**
- 16 - Motor winding terminal **A-**
- 17 - Motor winding terminal **A**
- 18 - Connection point for shield of motor shielded cable.

4) MAIN SETTINGS (Dip switches and jumpers)

Main setting **must be done by the user** at the installation or replacement time, according to motor type and working condition. Wrong setting could damage drive or motor and cause a not correct work of the motor.

► = Default settings

| NOMINAL CURRENT I_{NP} in Ampere (Dip 1, 2 and 3) | | | | | |
|---|-------|-------|-------|------------------------------|------------------------------|
| | Dip 1 | Dip 2 | Dip 3 | Current I_{NP} | |
| | | | | NDC 04 NDC 04.V NDC 94 | NDC 06 NDC 06.V NDC 96 |
| ► | ON | ON | ON | 0.65 | 1.9 |
| | ON | ON | OFF | 0.75 | 2.3 |
| | ON | OFF | ON | 0.9 | 2.7 |
| | ON | OFF | OFF | 1.0 | 3.1 |
| | OFF | ON | ON | 1.2 | 3.6 |
| | OFF | ON | OFF | 1.4 | 4.3 |
| | OFF | OFF | ON | 1.7 | 5.1 |
| | OFF | OFF | OFF | 2.0 | 6.0 |

Table 2

NOTE: For NDC 94 and NDC 96 models, remove the case to set FC, CO and J3 jumpers (see Fig. 6).

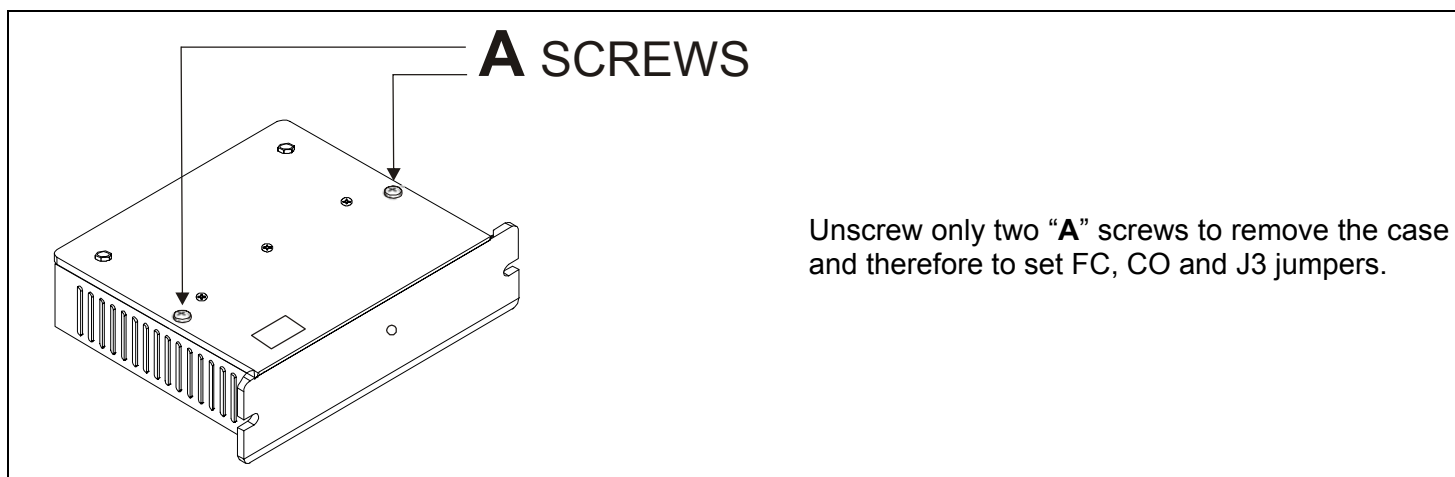

Fig. 6

| | JUMPER | | |
|---|----------------|------------|---|
| | FC | ON | Automatic current reduction disable |
| ▶ | FC | OFF | Automatic current reduction active |
| ▶ | CO | ON | Current off input forced to ON |
| | CO | OFF | Current off input available |
| | OS (J3) | ON | RUN operation mode – internal oscillator use |
| ▶ | OS (J3) | OFF | STEP operation mode –STEP and DIRECTION inputs |

Table 3

| DAMPING (Dip 4) | | |
|------------------------|--------------|--------------------|
| | Dip 4 | |
| | ON | ENABLED |
| ▶ | OFF | NOT ENABLED |

Table 4

Damping electronic circuit ensures low acoustic noise and a reduced amount of the motor mechanical vibrations typical of stepping motors. In any case these are reduced using higher steps /revolution setting compatibly with maximum frequency produced by control system and with maximum revolution speed requested to motor.

For example, with a control system with maximum frequency of 10 KHz, if a speed of 600rpm = 10 revolutions/sec needed, the maximum setting resolution is $10.000/10= 1000$ steps/rev.

a) STEP operation mode (JUMPERS OS/J3 NOT SHORTED)

| OPERATION MODE – STEPS FOR REV. (Dip 6, 7 and 8) | | | | |
|---|--------------|--------------|-----------------|------------------|
| | Dip 7 | Dip 8 | Dip 6 ON | Dip 6 OFF |
| | ON | ON | 4.000 | 3.200 |
| | ON | OFF | 2.000 | 1.600 |
| ▶ | OFF | ON | 1.000 | 800 |
| | OFF | OFF | 500 | 400 |

Table 5

DIP 5: RESERVED, SET OFF.

RUN operation mode (JUMPER OS/J3 CONNECTED)

| TABLE OF MOTOR SPEED IN RUN OPERATION MODE | | | | | |
|--|-------|-------|-------|----------------|---------|
| DIP 5 | DIP 6 | DIP 7 | DIP 8 | STEPS FOR REV. | RPM |
| ON | ON | OFF | OFF | 400 | 450 (R) |
| ON | OFF | OFF | OFF | 400 | 338 (R) |
| OFF | ON | OFF | OFF | 400 | 225 (R) |
| OFF | OFF | OFF | OFF | 400 | 113 |
| ON | ON | OFF | ON | 800 | 225 (R) |
| ON | OFF | OFF | ON | 800 | 169 (R) |
| OFF | ON | OFF | ON | 800 | 113 (R) |
| OFF | OFF | OFF | ON | 800 | 56 |
| ON | ON | ON | OFF | 1600 | 113 (R) |
| ON | OFF | ON | OFF | 1600 | 84 (R) |
| OFF | ON | ON | OFF | 1600 | 56 |
| OFF | OFF | ON | OFF | 1600 | 28 |
| ON | ON | ON | ON | 3200 | 56 (R) |
| ON | OFF | ON | ON | 3200 | 42 (R) |
| OFF | ON | ON | ON | 3200 | 28 |
| OFF | OFF | ON | ON | 3200 | 14 |

Table 6

DIP SWITCHES 5 and 6 set oscillator frequency, DIP SWITCHES 7 and 8 set resolution in steps/rev. The character **(R)** indicates a micro-ramp in starting and stop that improves START STOP performances of motors. In case of settings with equal speed in rpm pay attention that some are with micro-ramp and others without micro-ramp. The choice of the one with higher steps/rev produces a motor movement with less noise and with lower mechanical vibrations.

5) DRIVE STATUS BY LED

- LED HV green:** **ON** = supply voltage value in working range.
 OFF = no supply voltage or supply voltage out of working range
- LED FAU red:** **ON** = drive set in no working state by one of the following protection:
 a – Thermal protection, if LED TER is ON
 b - Max or Min voltage when LED HV is OFF
 c - Short circuit or wrong connection at motor output when LED HV is ON
 OFF = drive active provided that LED HV is ON
- LED TER yellow:** **ON** = drive set in no working state by thermal protection.
 OFF = drive active provided that LED HV is ON.

6) ELECTRO-MAGNETIC INTERFERENCE

Drive and all related cabling are source of E.M. interference (conducted and radiated). In order to comply to EEC directive 89/336 and related standards (EN61800-3) installation has to be done according to schematics in Fig 7 and following indications:

- Locate drives, power supply, transformer and related cables inside the same enclosure, which has to be hermetic to electromagnetic fields.
- Interpose a filter between the transformer primary and the main (CORCOM mod. 6VVK1). Locate the filter near the supply entrance. Use only shielded cable (outside the enclosure) for connecting motor and drive.
- Connection made to Protective Earth terminal (PE), shown in Fig.7, must be short and have the lowest possible inductance.
- Use a supply transformer with a metal shield between primary and secondary winding and connect this shield to earth.

7) FORCED COOLING

According to operating conditions (ambient temperature, current setting, duty-cycle) forced cooling can be necessary. The most sure method to evaluate if this need exists or not is to measure temperature of the drive heatsink; if this temperature is greater than 65 - 70 °C in the most unfavourable working conditions, you need a forced cooling to obtain a reasonable long life from drive.



NOTICES, HAZARDS AND CAUTIONS



- NDC series drives are BDM (Basic Drive Module) conceived for restricted distribution (EN 61800-3 Ch. 3.2). They are sub-assemblies without a direct function, foreseen to be integrated in a more complex machine or installation by a professional assembler. It is forbidden the direct use of this product by a final user.
- CE marking: Products here described conform to EEC/73/23, EEC/89/336 and further modifications, when correctly installed and used.
- They are intended to drive stepping motors with two phases, base step angle 1.8 degree and phase inductance between 1.0 and 12.0 mH. Use with different kind of motor is not allowed.
- Protection degree IP00 (EN 60529) for NDC 04, NDC 04.V, NDC 06, NDC 06.V models: Use only inside a protective enclosure able to avoid electric shock hazard. Main setting, connector insertion or extraction has to be done with drive switched off.
- Protection degree IP20 (EN 60529) for NDC 94 and NDC 96: this means that they must be located inside a protective enclosure meeting requirements of standards applicable in the specific application in which they are used. Settings and connector insertion or extraction has to be done at drive switched off. The drive generates some amount of heat. Take care of this in considering the total amount of heat generated in the enclosure in which the drives are located. In order to make easier air circulation in the drive, install the drive vertically (not turned upside down) with at least 5 cm of free space over and under the drive and 1 cm to the left and the right of the drive. Do not obstruct air gratings.
- Installation is allowed in local environment with pollution degree N° 2 (IEC 664-1). Installation in presence of explosive and/or flammable and/or chemically aggressive and/or electrically conductive gas, vapour or dust and installation near easily flammable or heat sensitive materials is strictly forbidden.
- Use for safety related functions is forbidden (EN 60204-1); it is also forbidden any application arrangement in which a driver fault or failure could generate an hazardous condition. It is forbidden to use this material in application covered from one or more EEC directive before the conformity to those directives has been declared.
- Residual voltages: depending on supply type (assembled by user) and application conditions, a waiting time greater than 5 seconds after switching off could be necessary.
- Scald hazard: due to the presence of some components operating at high temperature (120°C), wait some minutes after switching off in order to avoid scalds.
- Driver could generate electromagnetic interference (both radiated and conducted) if instruction about installation directions are not respected (chap. 6). We remember however that compliance to EEC 89/336 directive has to be tested on whole machine in normal working condition.
- Even if logic input and output signals connections are optically insulated, dangerous high voltage could appear on those connections in case of drive failure. For this reason, regarding to machine safety, you have to consider that a voltage equal to V_{DC} could be present at the I/O in case of failure.
- Insulation of the drive parts is dimensioned for pollution degree N° 2 and for overvoltage class II. The drive can't be connected to the main and it has to be power supplied by a power supply equipped with transformer main insulation.

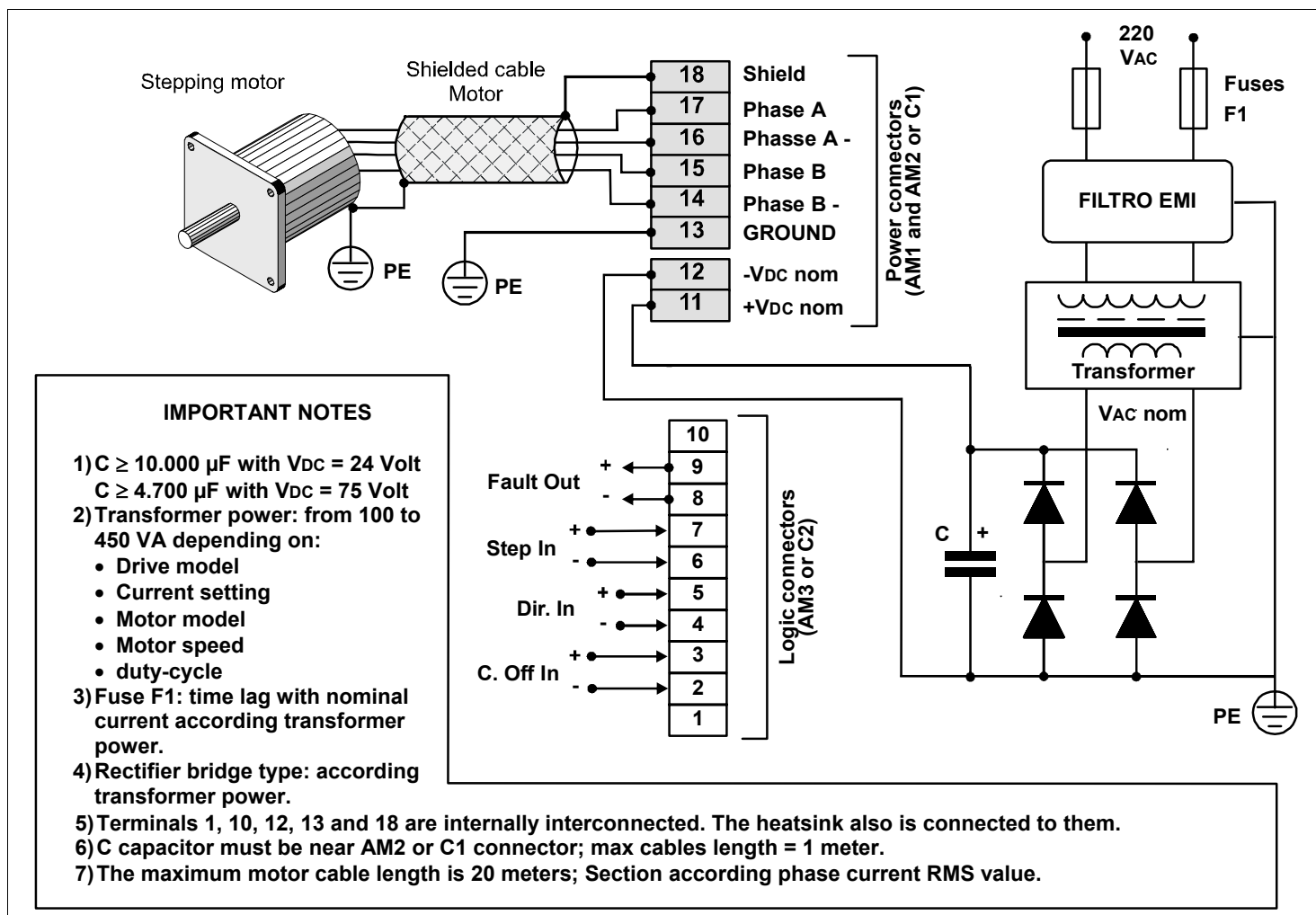

Fig. 7

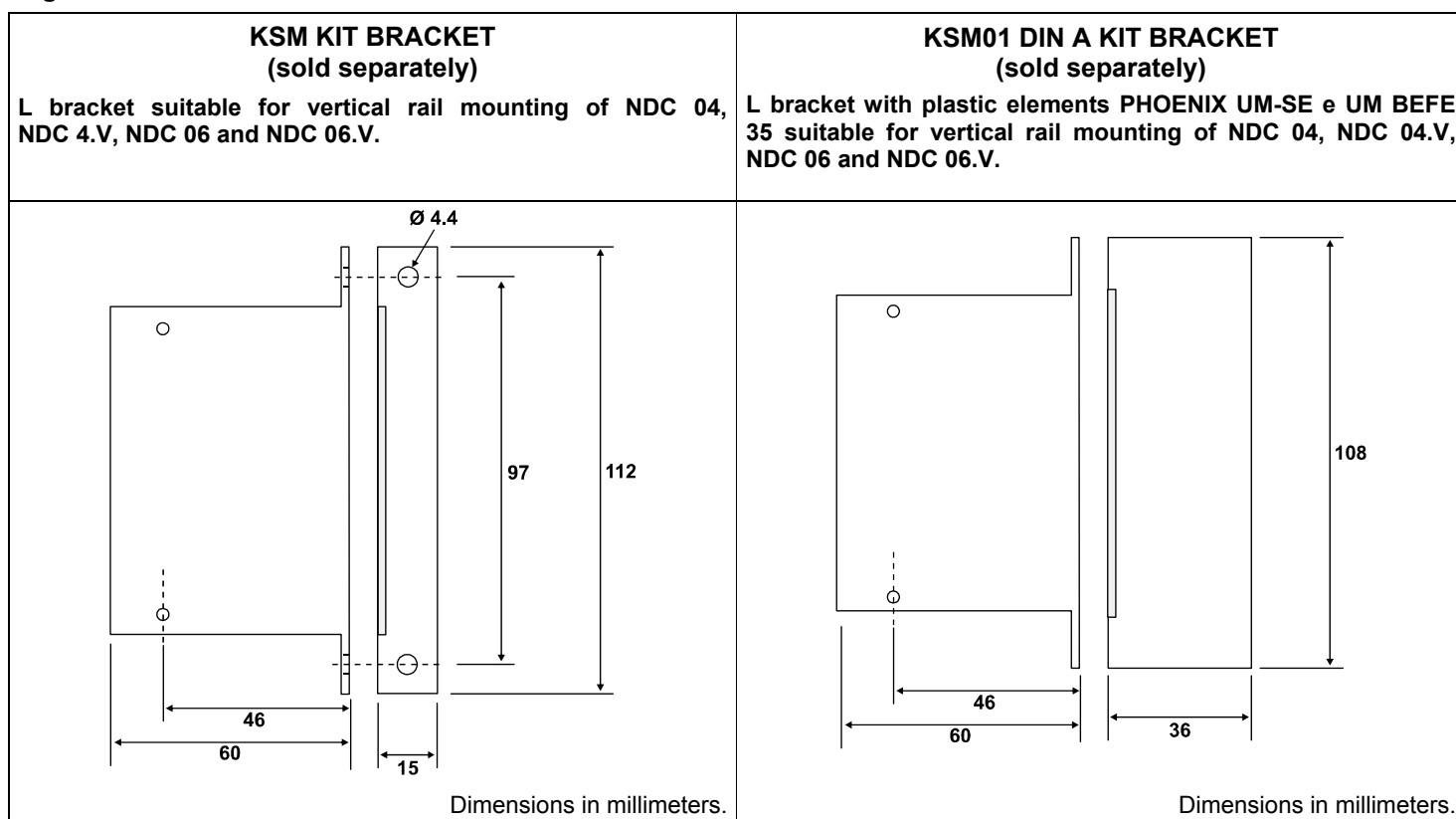

Fig. 8

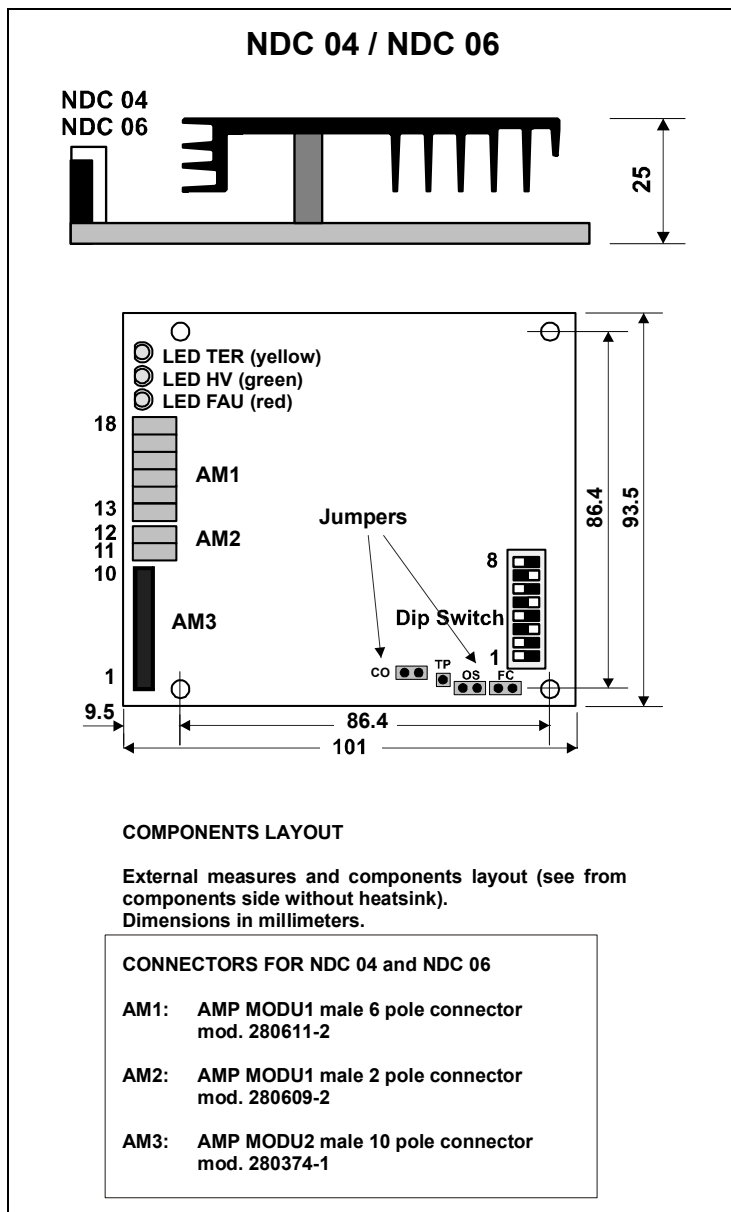

Fig. 9 a

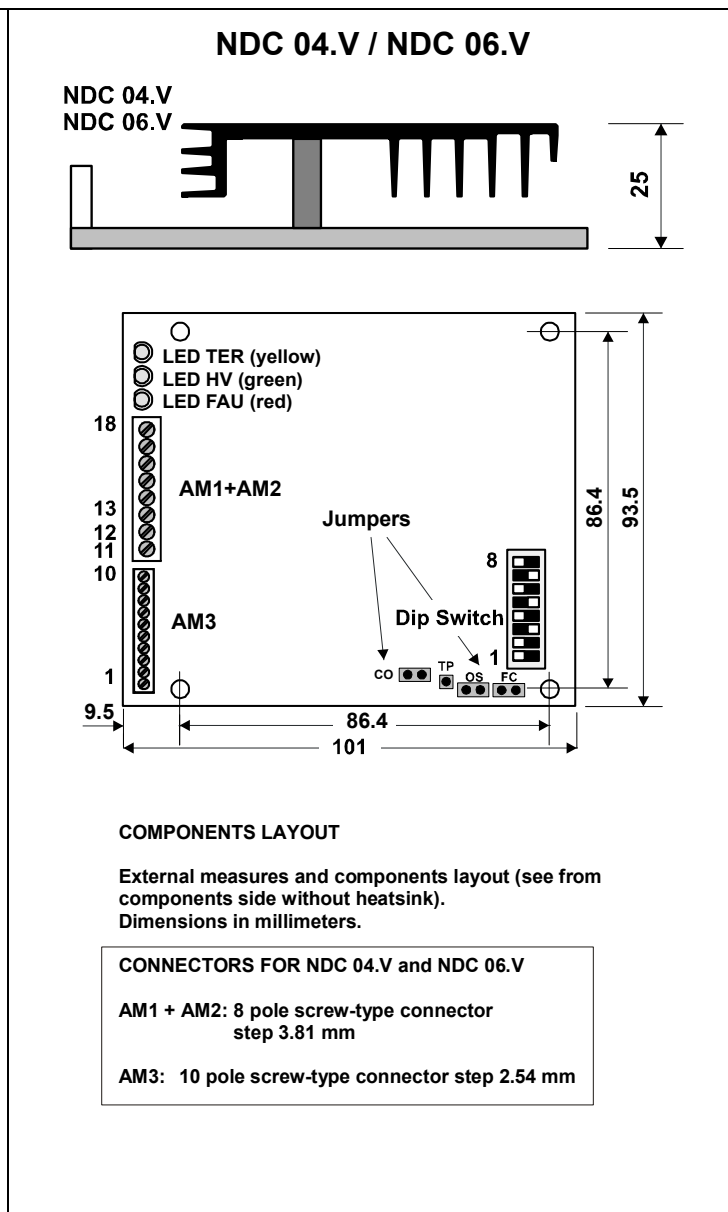

Fig. 9 b

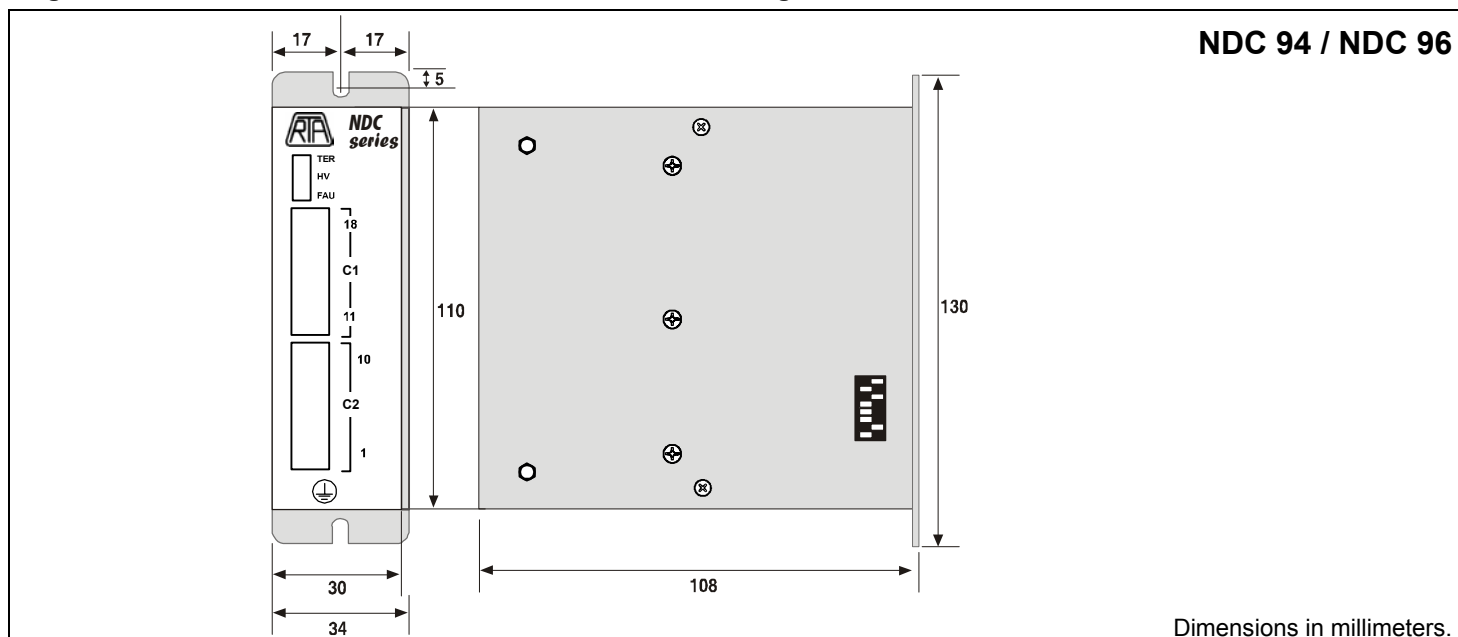

Fig. 10